

REVISIONS				
ZONE	REV.	DESCRIPTION	DATE	APPROVED
P	2.1	DUAL 1030 USED FOR X-AXIS	4/2/2014	CP

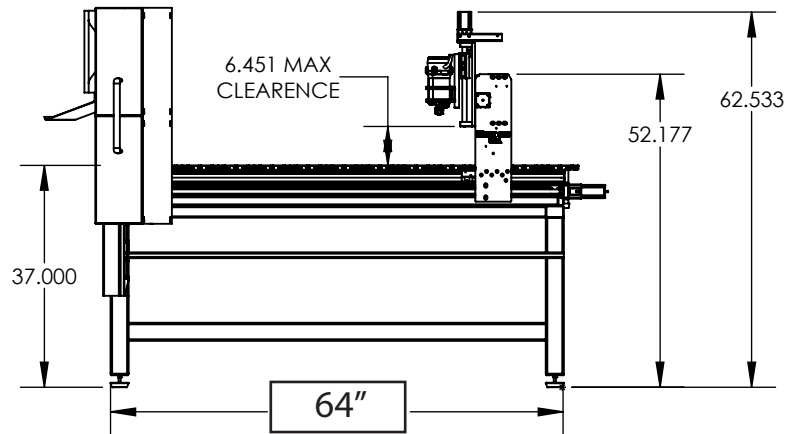
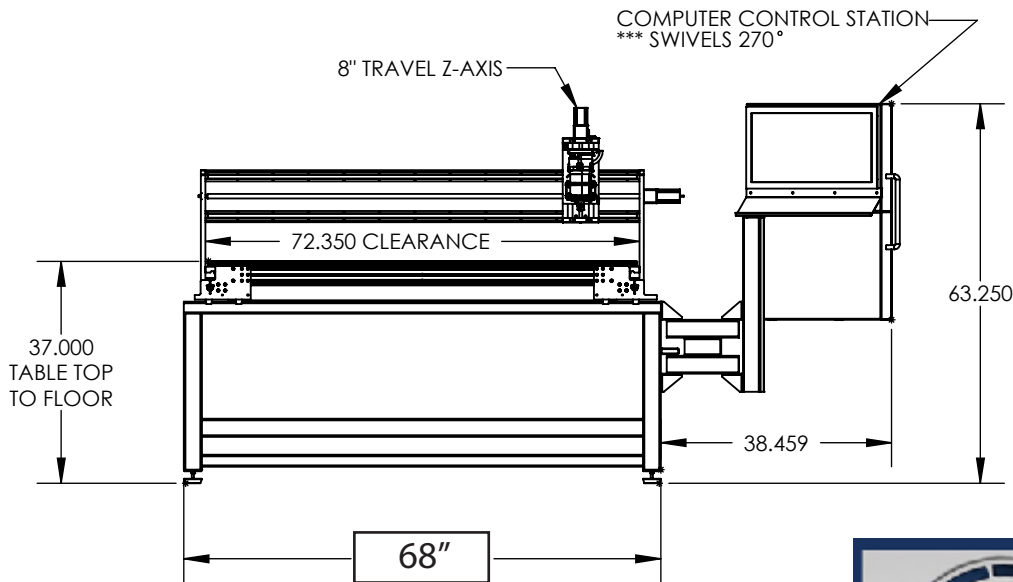
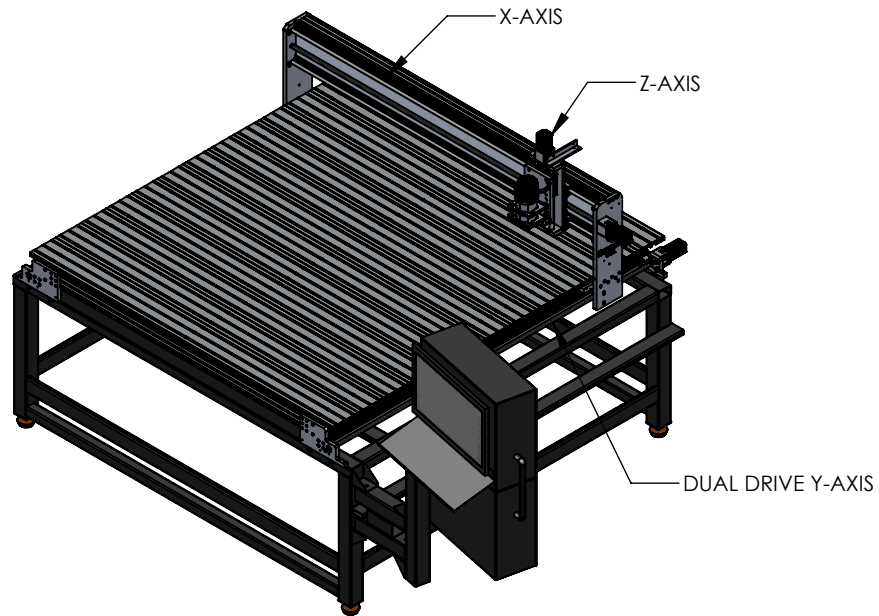
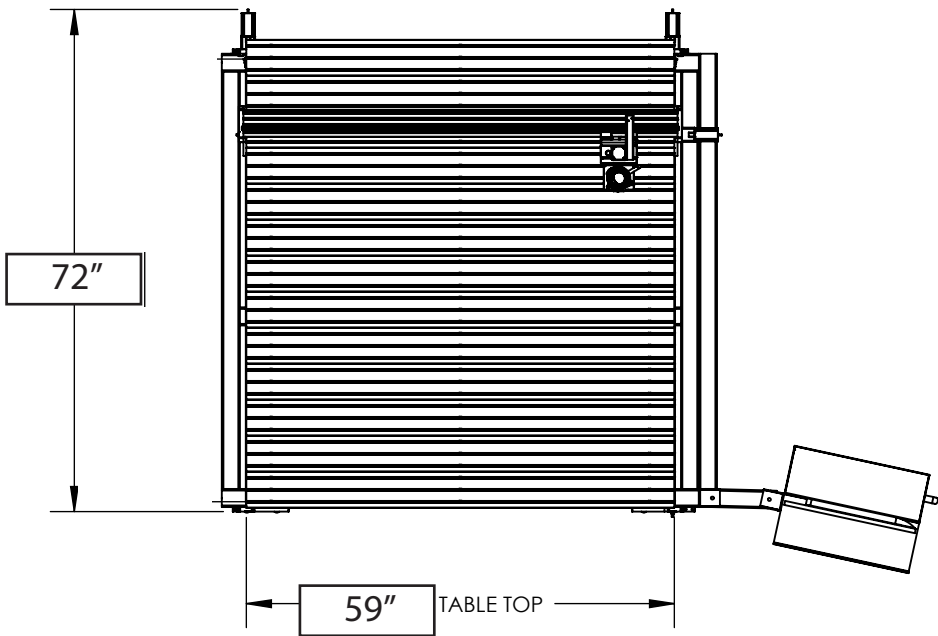

UNLESS OTHERWISE SPECIFIED:
 DIMENSIONS ARE IN INCHES
 FILLETS AND ROUNDS R
 HOLES THROUGH ALL
 INTERPRET GEOMETRIC TOLERANCING PER:
 MATERIAL VARIES
 FINISH
 DO NOT SCALE DRAWING

	NAME	DATE
DRAWN	CP	
CHECKED	RL	
ENG APPR.		
MFG APPR.		
Q.A.		
COMMENTS: MACHINE TRAVEL: X-AXIS = 62.000" Y-AXIS = 62.000" Z-AXIS = 8.000"		

VELOX CNC		
TITLE: VR5050 WSCS 2015 CURRENT MODEL		
SIZE	DWG. NO.	REV
A	VR-Series_Master_REV2.1	2.1
SCALE: 1:32 WEIGHT:		SHEET 9 OF 14